

Automation  
systems for  
rolling shutters

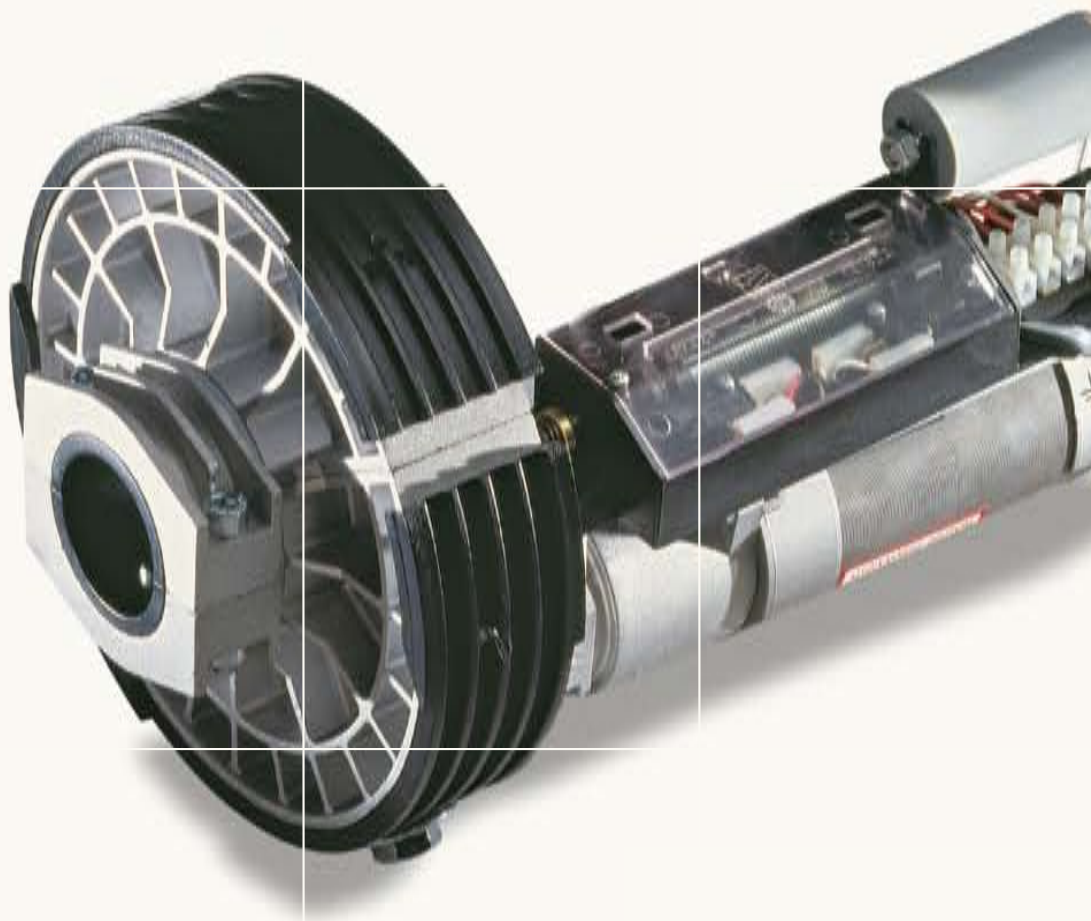

# H1000

**Flexibility of use and  
powerful lift,  
all in one model**

The H series automation systems are the optimal solution to provide automation to all types of rolling shutters without needing to modify the original structure of the shutters.



  
**CAME**  
AUTOMATIC GATES

# H1000

Modularity and performance for rolling shutters

A safe and easy-to-use system in one model, suitable for different types of posts and springs. The H series gearmotors allow for modular installation without the need to make any adaptations. For large-sized applications, CAME also provides a two-motor version to increase the lift power.

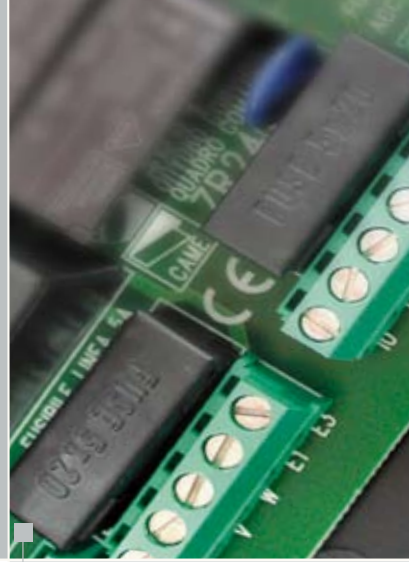

**Compliant with the applicable safety legislation standards.** The series H control panel is compliant with the current technical safety standards and comes complete with radio decoder for the remote control.

**Reliability to the maximum power.** The H1003 and H1103 gearmotors can be coupled with a second motor to increase the lift capacity.

**Versatile in every way.** All of the H series gearmotors are suitable for Ø 48 mm posts as well as Ø 60 mm ones, and for Ø 200 or 220 mm springs. All that is needed for the installation are the standard supplied accessories.

## The electronics

Besides the normal command and safety functions, the electronics of the Z24 control panel provide certain details that offer total control of the automation device as well as optimal duty performance, such as:

- > **Auto-learning of the radio code between transmitter and receiver**
- > **Pre-set automatic closing using the specific adjustable trimmer**
- > **“Maintained action” command which requires constant pressure on the command button for the duration of the opening or closing phase**

## The models

- H1003**  
230V A.C. IRREVERSIBLE Gearmotor complete with pull-cord release.
- H1103**  
230V A.C. REVERSIBLE Gearmotor.
- H2003**  
230V A.C. IRREVERSIBLE Gearmotor with double motor complete with pull-cord release.
- H2103**  
230V A.C. REVERSIBLE Gearmotor or with double motor.

## Dimensions:

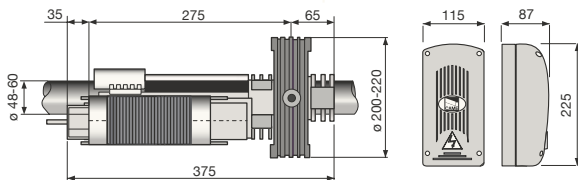

## Accessories:

- H3100** Supplementary 230V gearmotor.
- H3012** Electroblock for REVERSIBLE gearmotor.
- H3001** Safety casing complete with release pull-cord handle and command button.
- ZR24** Dedicated control panel.

## Technical features:

Type	H1003	H1103	H2000	H2103
Degree of protection	IP40			
Motor power supply	230V A.C. (50/60 Hz)			
Absorbed input	2,4A	4,5A		
Max. power	270W	500W		
Reduction ratio	1/150			
Operation intermittence	30%			
RPM	9 rpm			
Lift capacity	120 kg	200 kg		
Operating temperature	-20°C ÷ +55°C			

## Standard installation:

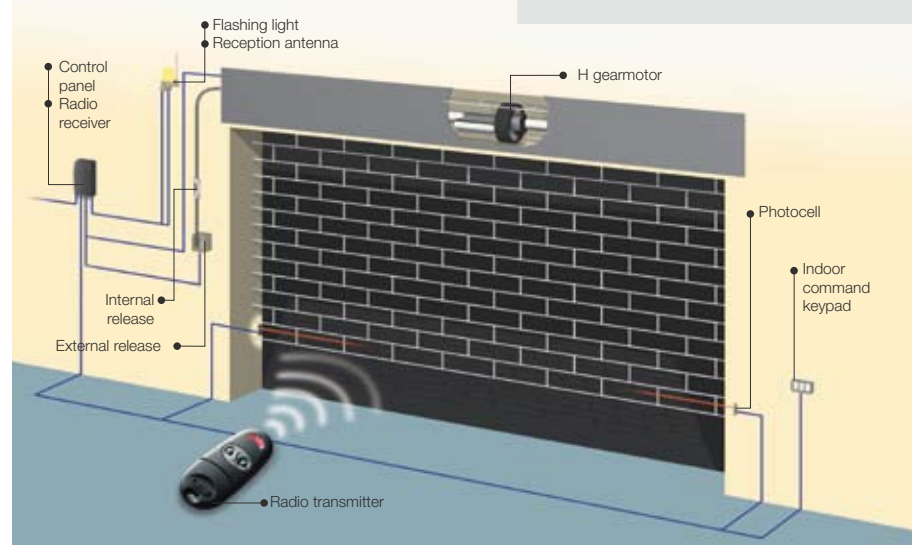

In the event a careful analysis of the automated gate's risks were to require it, the use of sensitive safety infrared or contact profiles becomes indispensable.



Made in Italy



Came cancelli automatici s.p.a.

via Martiri della Libertà, 15  
31030 Dosson di Casier - Treviso - Italy

www.came.it - info@came.it

